

Kent Diamond Tactile Warning Stud

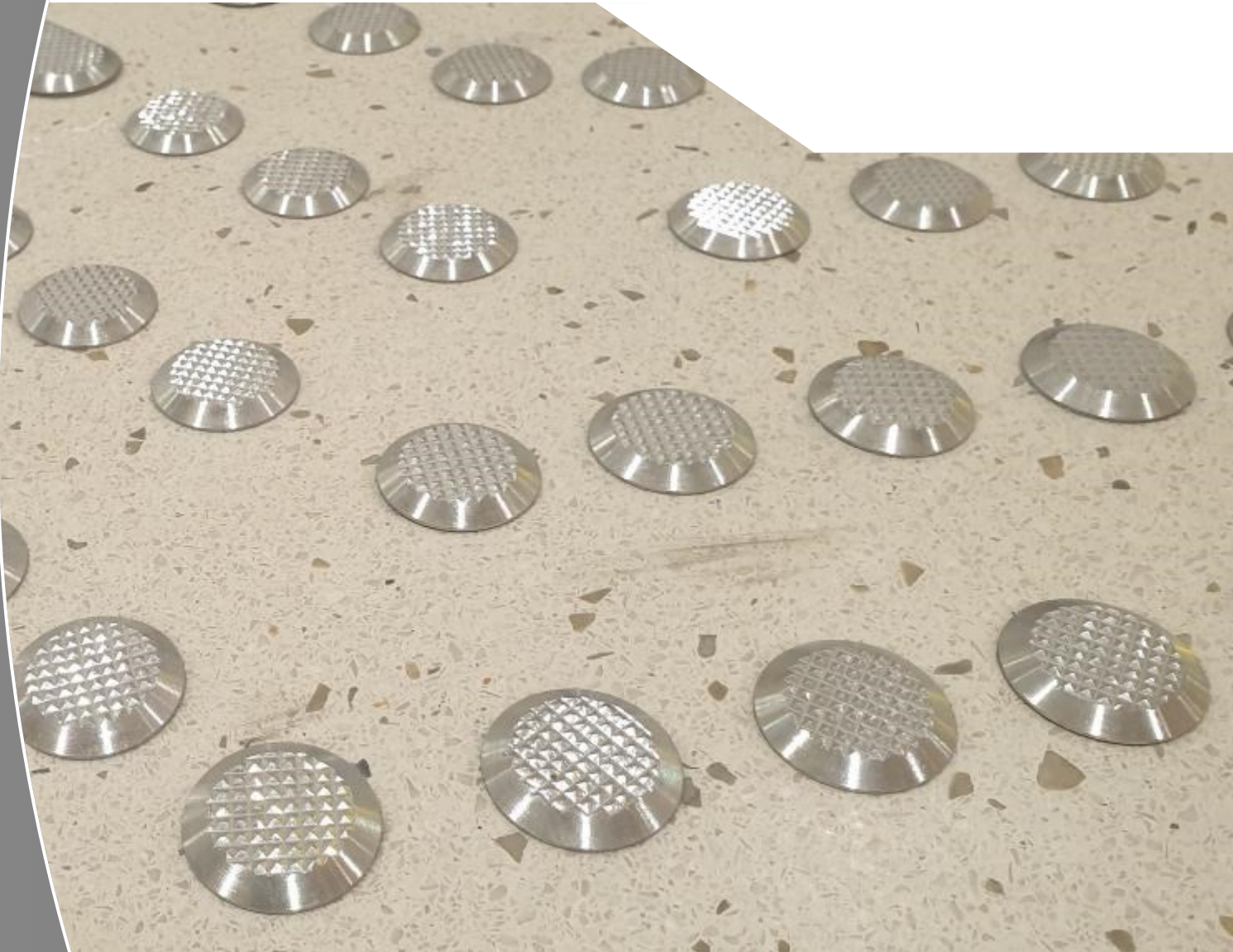

KENT DIAMOND TACTILE WARNING STUD (KDTWS 35)

Specify:

Kent Diamond Tactile Warning Stud (KDTWS 35); Grade 316 Stainless Steel; Dia: 35mm, Height: 5mm; 1nr 6mm dia x 15mm high studs, Polished Finish;

Description:

Kent Diamond Tactile Warning Stud provides an underfoot warning to identify hazards and dangerous areas where there is a change in levels or where there is an unprotected opening such as open stairwells and platforms. The stainless steel material is ideal for high-traffic pedestrian areas. The slip resistant design ensures the studs do not themselves become a hazard in wet or cold conditions.

The Kent Diamond Tactile Warning Stud is also available in a 420mm long x 35mm wide Strip version which you can see on our website: [Kent Diamond Tactile Warning Strip](#)

Features:

- Grade 316 Stainless steel
- 35mm dia x 5mm Thick Steel
- Diamond Anti Slip Disc
- Polished Finish
- 1 Installation pins

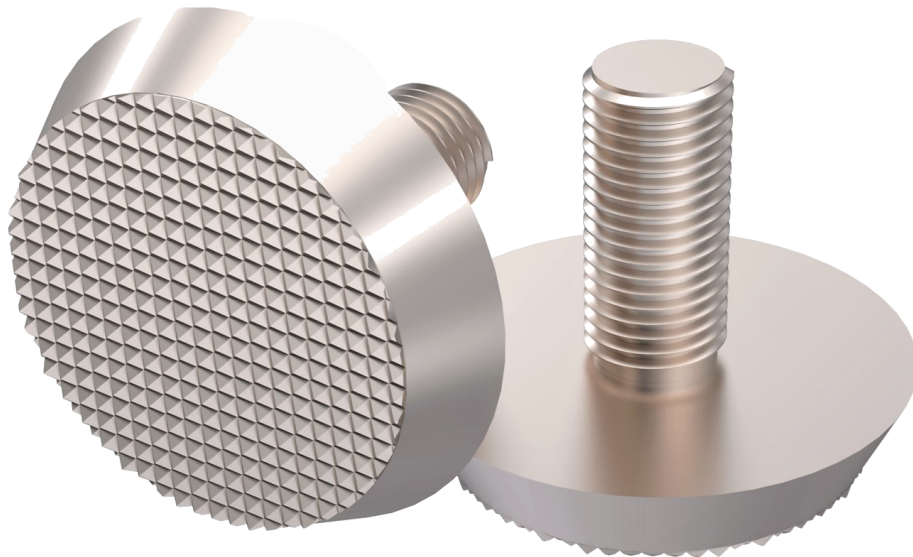

KENT DIAMOND TACTILE WARNING STUD (KDTWS 35)

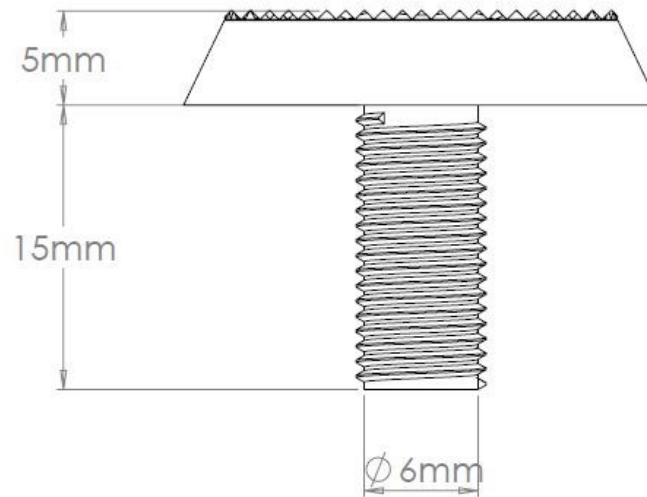
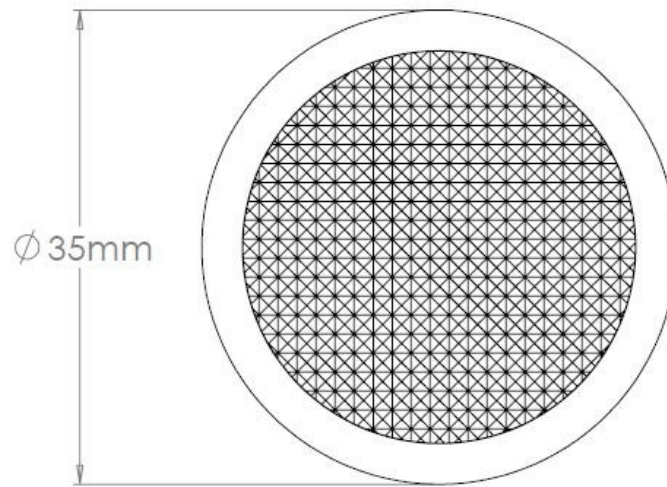

Product Code	Diameter	Height
Kent Diamond Tactile Warning Stud KDTWS 35	35mm	5mm

Installation of Studs

Step 1:

Drill x1 10mm Diameter hole 20mm deep.

Step 2:

Clean out the drilled hole.

Step 3:

Fill with chemical mortar (Kent Stainless recommend MIT-SE Mortar).

Step 4:

Insert the Kent Diamond Tactile Warning Stud and leave to set for 24 hours

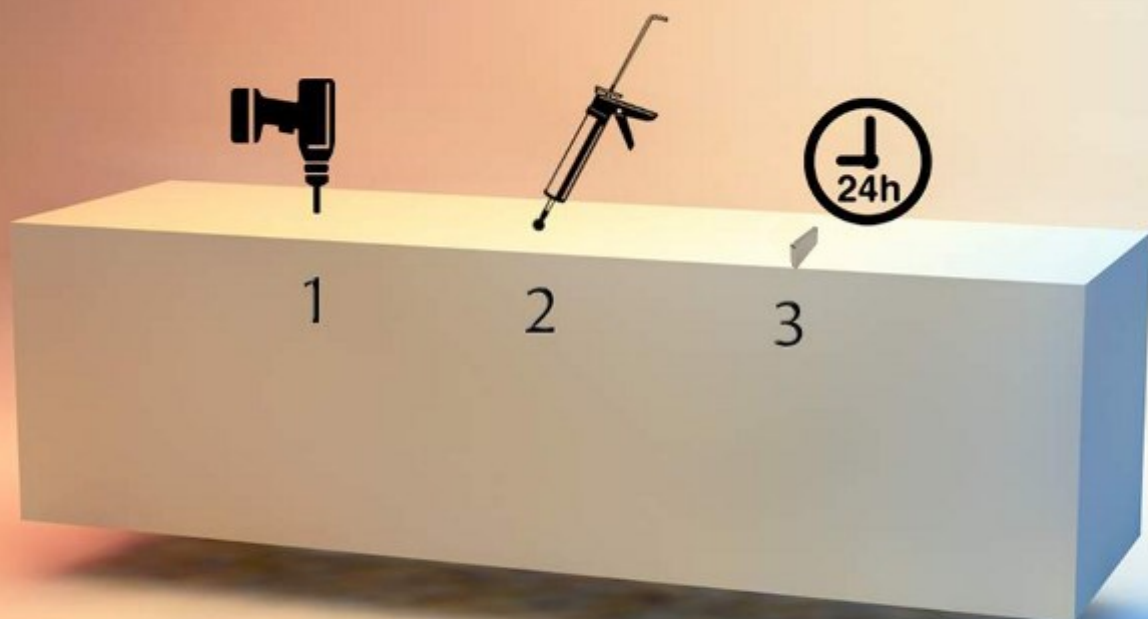

Specify

Choose your steel:
Grade 304 Stainless steel
Grade 316 Stainless steel

Specify:

Kent Diamond Tactile Warning Stud (KDTWS 35); Grade 316 Stainless Steel; Dia: 35mm, Height: 5mm; 1nr 6mm dia x 15mm high stud, Polished Finish;



Maintenance of Stainless Steel

Clean the stainless steel components using warm water with a mild detergent with a non-abrasive cloth or sponge. Heavier stains may require the use of a nylon-scouring pad or a stainless steel cleaner.

To remove paint or graffiti use a cloth and Alkaline or solvent paint strippers according to type of paint. In the case of a bead blasted finish, where abrasive cleaning is required, always use a random circular rubbing action with a cloth.

In the case of brushed finishes the surface consists of uniform fine 'scratches' running in one direction so where abrasive cleaning is required always use a straight back and forward rubbing action in the direction of the grain using soap and warm water.

Rust spots or 'tea stains' can occur on the surface of the material, these are normally caused by contamination from ordinary mild steel, particularly in areas where construction work has been undertaken. Such stains can be removed using Rust Remover 410.

In cases where the surface is severely stained because of severe environmental conditions or scratched due to misuse, it may still be possible to restore the original finish using chemicals such as Oxalic Acid solution. There are many stainless steel polishes available to enhance the surface finish.

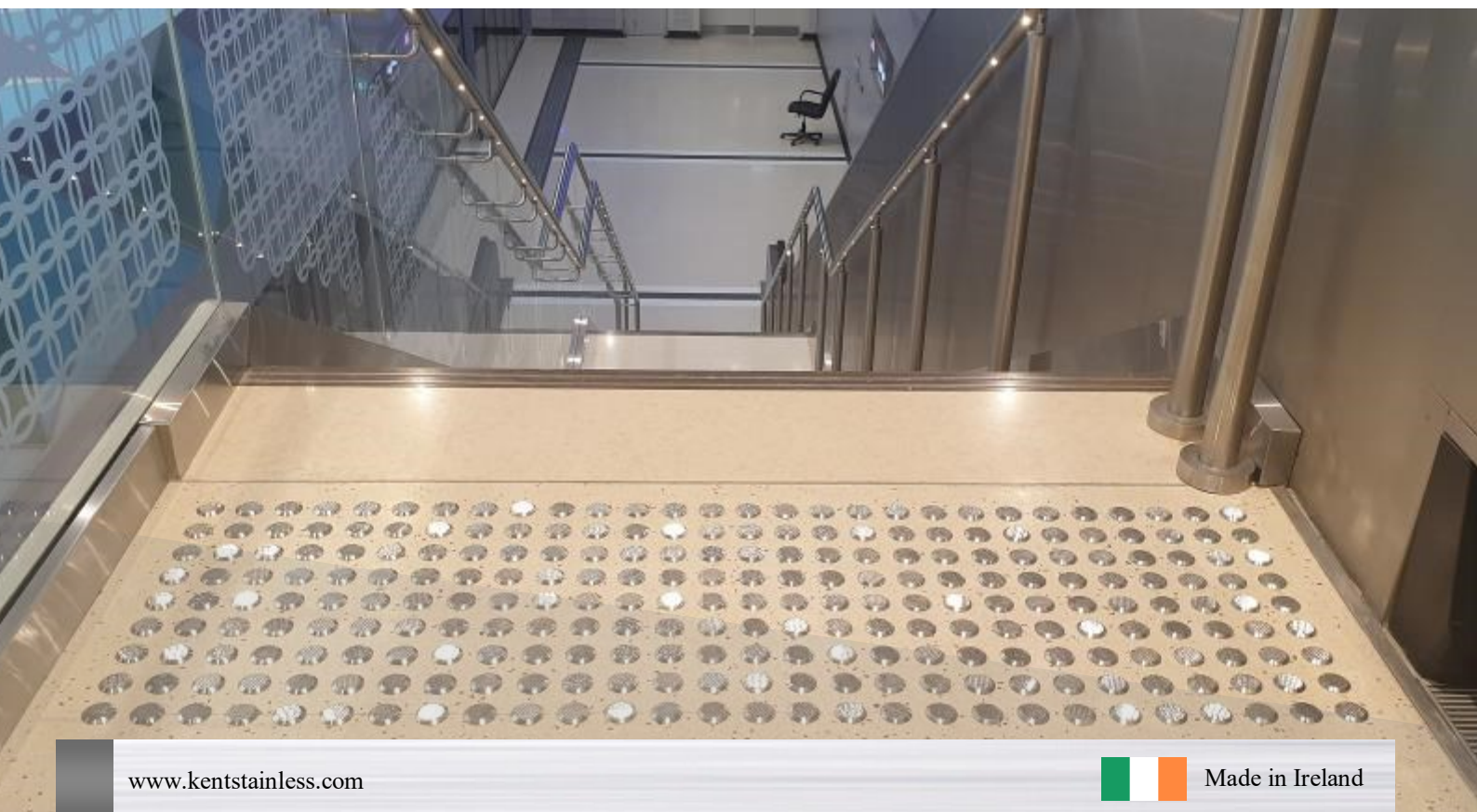

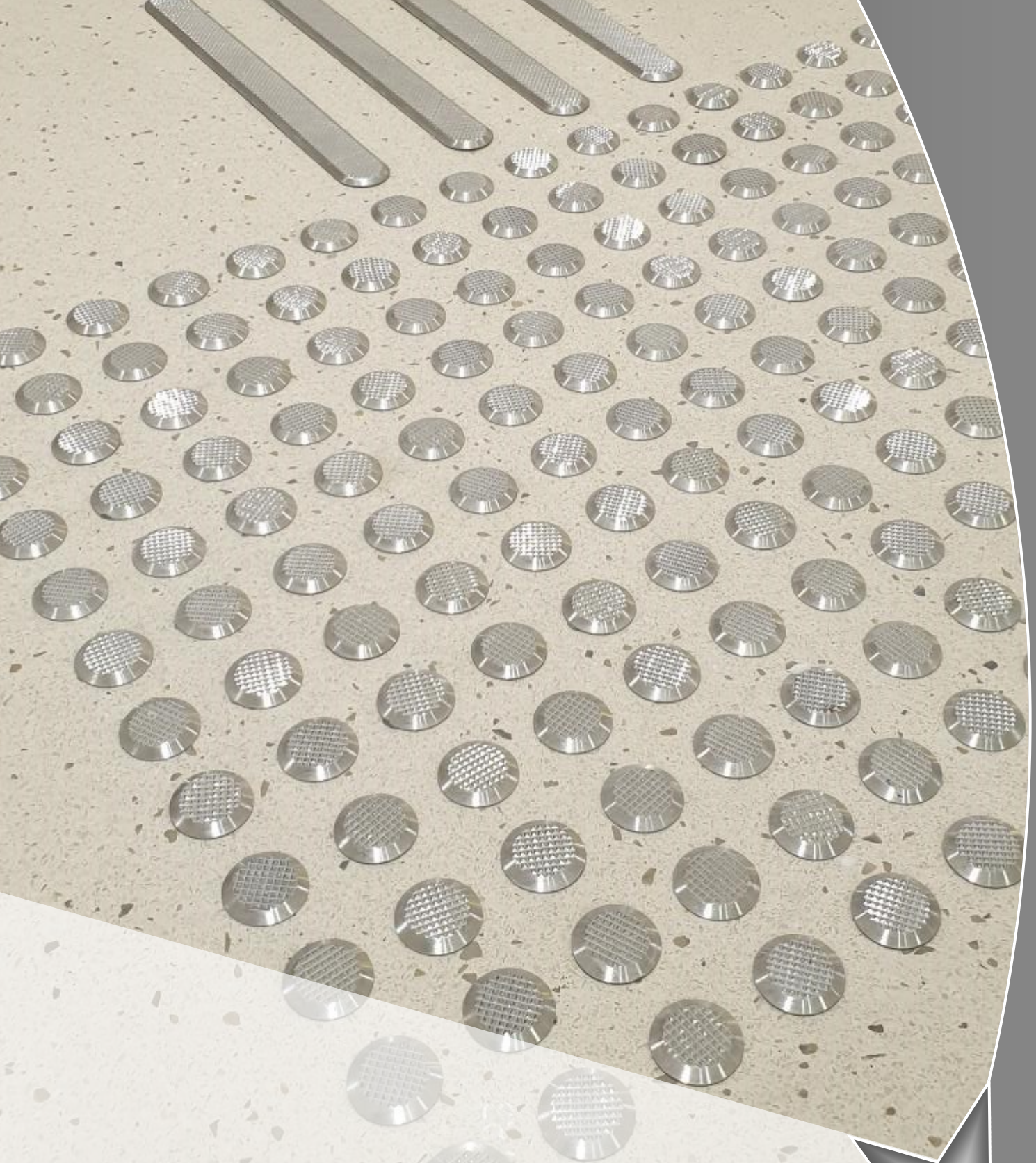

Kent Stainless Ltd

Ardcavan, Wexford, Ireland

TEL NO: +353 53 9143216
UK FREEPHONE: 0800 376 8377
FAX: +353 53 9141802
WEB: www.kentstainless.com
EMAIL: info@kentstainless.com

